



Manufacturer: TMK sp.j. Września
Szosa Witkowska 105
tel./fax +48 61 437 97 60
www.tmk.com.pl

CH circulating pump controller

SP 100

Installation and Operation Manual



CE

APPLICATIONS

Electronic controller SP 100 is the unit for the CH pump automatic start and stop. The controller can be used for pumps in CH installation with the gas heated or solid fuel heated boiler. Controller starts the pump when temperature reaches the preset value on scale. When the boiler is burnt out the pump stops what makes that heaters remain warm longer reducing the energy consumption.

Example installation

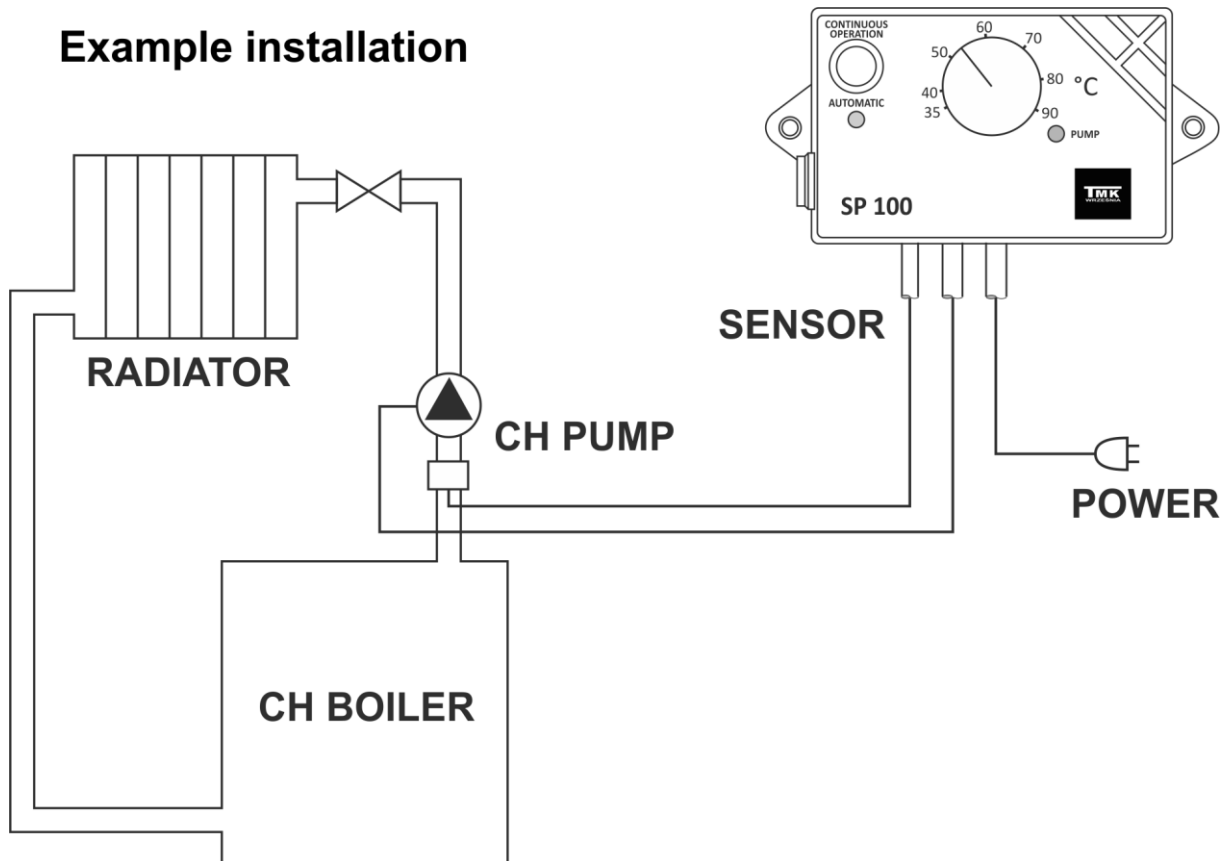

INSTALLATION

1. Controller mounting

Mount the controller on a suitable wall near the CH boiler, using 6 mm wall plugs (the plugs complete with screws are a part of the delivery set).

2. CH sensor mounting

- Mount the sensor on a non-insulated pipe going out of the CH boiler.
- Fasten the sensor to the pipe using two clamps (included in the delivery set) so that it adheres properly to the pipe.
- It is advisable to wrap the pipe with the sensor with a thermal insulation material.

Note: The sensor is not suited for being used directly in the liquid!

3. Connection of power supply cable to the pump

- Connect the green-yellow wire (protective neutral conductor) of the 3-wire supply cable to the protective neutral terminal of the motor (marked with an appropriate symbol);
- Connect the brown and blue wires to the L and N terminals of the motor;

4. Controller connection.

Connect the supply cable to a 230 V, 50 Hz power outlet with an earth contact.
The ambient temperature in the controller mounting location may not exceed 40°C.

Note: The connection cable of the regulator may only be replaced by the manufacturer.

Note: Always ensure that regulator installation is performed by a properly qualified electrician.

CONTROLLER OPERATION

1. With the switch marked “**continuous operation – automatic operation**” you can choose between two operating modes of the circulating pump:

1) Automatic operation mode:

- The green signal lamp marked “automatic” lights up,
 - The controller activates or deactivates the pump depending on the sensor temperature,
 - The temperature of pump activation can be set with a control knob,
 - The circulating pump operates at higher temperatures than the temperature preset in the scale.
- When the boiler is shut down and the sensor temperature drops, the pump switches off.

2) Continuous operation mode:

- The green signal lamp goes out and the red signal lamp lights up,
- The pump operates in the continuous mode (e.g. to check pump operations with a cold boiler).

2. If the red signal lamp is lit, the pump is operating.

PUMP PROTECTION

The pump and the controller are protected with a 500 mA fuse which blows in emergency situations (e.g. short-circuit within the pump or in the controller).

DELIVERY SET

- controller
- clamps (2 pcs.)
- 6 mm wall plugs (2 pcs.)

NON-STANDARD APPLICATIONS

The SP 100 controller can also be used for controlling a circulating pump in CH systems with a gas-fired boiler. In this type of application, the temperature of exhaust gases evacuated through the chimney must be measured. If you are planning to use the SP 100 in this type of application, please contact TMK sp.j. for free information and advice.

WARRANTY

TMK sp.j. grants the user a warranty for the SP 100 controller. The warranty period is 3 years from the date of purchase of the device, however not longer than 4 years from the date of manufacture.

WARRANTY TERMS AND CONDITIONS

Warranty claims shall be accepted provided that the terms and conditions of warranty, and general rules of operation of electronic devices, are complied with as required. TMK sp.j. guarantees appropriate workmanship, high quality and reliable operation of the controller. In the event of any faults in the controller's operation, or defects which can be attributed to the manufacturer, TMK sp.j. shall repair or replace the faulty controller with a defect-free device within 14 working days from the date of returning the controller (in person or through post). The warranty scheme explicitly excludes all defects arising due to the user's fault and, particularly, defects caused by mechanical damage, faulty mounting, water ingress or operation of the device contrary to the general rules of operation of electronic devices.

The warranty is only valid with a proof of purchase.

DATE OF SALE:

.....
day, month, year

.....
Seller's stamp and signature

MANUFACTURER:

TMK sp.j.
62-300 Września
Szosa Witkowska 105
tel./fax + 48 61 437 97 60
www.tmk.com.pl

.....
DATE OF MANUFACTURE